

Branch Offices:

AHMEDABAD

B-802, Iscon Elegance, Nr. Prahlad Nagar Corner, Opp. Karnavati Club, S.G. Highway, Ahmedabad-380051
Ph.: 079 - 66168835/36
E-mail: ahmedabad@hplindia.com

BANGALORE

No.2D, IIInd Floor, Farah Winsford, 133, Infantry Road, Bangalore - 560001
Ph.: 080-22863068/69
E-mail: bangalore@hplindia.com

BHUBANESWAR

The Metropolis, Plot No. A- 167, Saheed Nagar, Bhubaneswar - 751007 (Orissa).
Ph.: 91+ 9861374379, 8018027834
E-mail: orissa@hplindia.com

CHANDIGARH

SCO-14, 1st Floor, Industrial & Business Park, Phase-II, Chandigarh-160002
Ph.: 0172-2639157/ 8146404442
E-mail: chandigarh@hplindia.com

CHENNAI

"Amar Sindur" S-4, 2nd Floor, No.-43, Pantheon Road, Egmore, Chennai-600 008
Ph.: 044-28551530, 28551537
Fax: 044-42638243
E-mail: chennai@hplindia.com

COCHIN

1st Floor, A.K.S. Mahal Building, XL/7813J, Achutha Warriar Lane, M.G.Road, Ernakulam, Cochin-682035
Telefax: 0484-2354595
E-mail: cochin@hplindia.com

DEHRADUN

09/4/6, 1st Floor, East Canal Road, (Near Doon Defence Academy) Dehradun-248001
Ph.: 0135-2664387, 2664367
E-mail: uttranchal@hplindia.com

GUWAHATI

Rajgarh Road, Opposite China Town Restaurant, Guwahati-781003
Ph.: 0361-2450889
E-mail: guwahati@hplindia.com

HYDERABAD

No. 7-1-58, Flat No.403, 4th Floor, Concourse Building, Green Lands Road, Hyderabad-500016,
Ph.: 040-66687878
E-mail: hyderabad@hplindia.com

INDORE

203, Millinda Manor 2, RNT Marg, Near Ravindra Natya Grah, Indore-452001,
Ph.: 0731-4280525, 4225540
E-mail: Indore@hplindia.com

JAIPUR

512, 5th Floor, Plot No. 8-9, Corporate Park, Gopal Bari, Ajmer Road, Jaipur-302001
Ph.: 0141-4021035
E-Mail: jaipur@hplindia.com

KOLKATA

69, Ganesh Chandra Avenue, India House, 7th Floor, Block-C, Kolkata-700013
Ph.: +91 9038094379
E-Mail: calcutta@hplindia.com

LUCKNOW

1st Floor, Jain Building, 14/A5, Park Road Hazratganj, Lucknow-226001
Ph.: 0522-4021687
E-Mail: lucknow@hplindia.com

MUMBAI

2C/H, Rushabh Chambers, 2nd Floor, Off-Makwana Road, Near Rubi Hotel, Marol, Andheri East, Mumbai-400059
E-mail: mumbai@hplindia.com

NAGPUR

Jagtap House, Plot No. 07, 1st Floor, Ganesh Gruh Nirman Society, Near Ganesh Mandir, Ring Road, Pratap Nagar, Nagpur-440022,
Ph.: 0712-2222988
E-mail: nagpur@hplindia.com

PATNA

Hem Plaza, 5th Floor - 510, Frazer Road, Patna-800001(Bihar),
Ph.: +91 9334697299
E-mail: patna@hplindia.com

PUNE

Sunrise Skyline 3rd Floor, Plot No. 28/2 Scheme No. 11 B Opp. MSEP Office Somwar Peth Pune-411001 Ph.: +91 9028032724
E-mail: pune@hplindia.com

RAIPUR

1st Floor, Near Holy Heart School Chattisgarh College Road, Civil Line, Raipur (C.G.)-492006,
Ph.: 0771-4218002/04
E-mail: raipur@hplindia.com

VADODARA

409/410, Silver Oak Complex, Near Shrenik Park, Char Rasta, Productivity Road, Akota, Vadodara - 390020 Gujarat
Ph.: 0265-4000583, Fax:0265-2352107
E-mail: baroda@hplindia.com

VIJAYAWADA

D.No.-29-37-135, 2nd Floor, G. R. Plaza, Eluru Road, Beside Canara Bank, Vijayawada-520002 Ph.: 0866-6622291
E-mail: vijayawada@hplindia.com

Resident Offices:

Agartala	Balasore	Cuttack	Jamshedpur	Malda	Rajkot	Tirupati
Agra	Belgaum	Davangere	Jalandhar	Mangalore	Rourkela	Trichy
Allahabad	Berhampur	Durg	Jharsuguda	Meerut	Salem	Trivandrum
Anantpuram	Bhilai	Goa	Jodhpur	Moradabad	Silchar	Udaipur
Aurangabad	Bhopal	Gorakhpur	Kanyakumari	Mysore	Siliguri	Vapi
Amravati	Bilaspur	Gulbarga	Kolhapur	Nagercoil	Surat	Varanasi
Akola	Bijapur	Hubli	Kota	Nasik	Sholapur	Vellore
Angul	Calicut	Jabalpur	Ludhiana	Patiala	Srinagar	Vizag
Bareilly	Coimbatore	Jabli	Madurai	Pondicherry	Sambalpur	

HPL/ONLCS/02-23



AV On Load Changeover Switches from 63A to 3150A



HPL Electric & Power Ltd

Corp. Office: Windsor Business Park, B-1D, Sector-10, Noida, U.P. - 201301, INDIA.
Tel.: +91-120-4656300, Fax: +91-120-4656333
Registered Office: 1/20, Asaf Ali Road, New Delhi - 110 002, INDIA.
E-mail: hpl@hplindia.com

Customer Care No. :
18004190198

www.hplindia.com



- Arc Chute
- Terminal Shroud
- Phase Separator

www.hplindia.com



On Load Changeover Switches



Highlights

- ▶ Conforms to IS/IEC:60947-3.
- ▶ Available in 6 frame sizes... rated current from 63A to 3150A in 3 Pole & 4 Pole versions.
- ▶ Universal Terminals compatible for both Aluminum and Copper Bus or Thimble.
- ▶ Quick Make & Quick Break manual independent mechanism (spring loaded mechanism).
- ▶ Bounce free type spring loaded contact.
- ▶ Fixed type operating Shaft, with & without Extensions.
- ▶ Arc chute plates to enhance contact life.
- ▶ High Mechanical & Electrical life.
- ▶ 100% Neutral rating... true 4 pole switch.
- ▶ Clear indication of 'ON', 'OFF' and 'ON' Position (I - O - II).
- ▶ Line load reversibility.
- ▶ Vertical or lateral mounting.
- ▶ For Retrofit Spacer is available in packing.
- ▶ Total safety : All moving and live parts shrouded. Terminal shroud, source separator, phase barrier as standard feature.
- ▶ ROHS Compliant.
- ▶ Wide range of accessories.

Application

The HPL make Onload Changeover Switch is 3 & 4 Pole manually operated, consisting of two sets of terminals for connecting to two incoming supply sources ensuring safe changeover from one source to another and is suitable for use in individual enclosures, switch boards, lighting & power panels etc. with following features :-

- Suitable for incoming and outgoing Power Distribution feeders.
- 3 stable positions (I - O - II) completely isolated with each other.
- Bridging bars mounted on all ratings as standard feature, no hidden cost of arranging shorting links additionally.
- Pre-equipped with terminal shroud, source separator, phase barrier with all ratings at no add-on cost.
- Supports easy maintenance unlike zig-zag terminals.
- Quick Make & Break type most safe transition & Bounce free contacts.
- Resistant to Tropical conditions, conductors, mold & enclosure designed considering safety.
- High thermal & dynamic stress withstand capacity.
- Self extinguishing fiberglass re-inforced insulating body.
- Available in Open execution, Steel sheet Enclosure & Direct Mounted.
- AC 23A Category.
- Any pole can be used as Neutral pole... true 4 pole switch.
- Unique Safety Handle with built in padlock facility
- 3 lock pad lock, lockable in ON & OFF positions.
- High Electrical & Mechanical life.

Approvals & Test

- Time tested
- Customer Accepted
- CPRI Tested
- ISO 9001 Certified



Globally Accepted
exporting to over
25 countries



On Load Changeover Switches



Advantages



Compactness

It is compact in size yet with universal terminating contacts helps in saving space in the enclosures, panels etc. Due to smaller footprint it uses the distribution space very efficiently regardless of fact whether it is installed in residential or industrial functional buildings.



Installer & User friendly

Its handling is easy and simple. Its simplicity and ease of use allows the user for quick installation. Any pole can be used as Neutral pole. Line load reversibility provides flexibility for incoming and out going connections. Plugin auxiliary contact kit easy to mount on the switch. Grove to insert safety shield.



Total Safety

Its is very safe to use. all moving parts and live parts are covered eliminating possibilities of casualties & electric shocks. The insulation property of the material used is highly reliable, self extinguishing with high insulating properties and remains intact in even critical conditions. arch chute chamber evades fire during operations.

Isolation Function:

These Onload changeover switches are **Suitable for Isolation** as per IS/IEC 60947-3. Isolation function highlights the following points:-

- Position of main contact is indicated clearly by a separate mechanical indicator.
- No residual current, all poles isolate with fool proof interlock between isolators.
- Pad lock evades incidents of accidental switching.



Positive isolation
no room for surges





Compact Design Total Safety

Double Break Switch
RoHS Compliant



- Source Cover, Terminal Shroud & Phase barrier as standard feature with product.
- Enclosed operating rod.
- Self extinguishing fiberglass re-inforced insulating body.
- 3 lock pad lockable handle in both ON & OFF positions.



Self Fire Extinguishing

- High thermal and dynamic with stand capacity with self extinguishing fibreglass insulating body.



Load Line Reversibility

- Quick make quick break.
- All poles rated 100%.
- In coming and outgoing easily interchangeable at site.

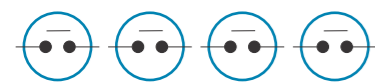

Positive Isolation

- Double breaking system.
- Emergency breaking.
- Safe isolation of downstream loads for maintenance.



Working Principle:

Stationary contacts are fixed to the molded housing in all rating switches. 4 sets of moving contacts housed in a carrier are moved towards right for ON & left for OFF. The moving contacts slide on to the stationary contacts to make the circuit. The contacts and the mechanism to move contact carrier are spring loaded to ensure Quick Make & Break and minimum arc formation. Double breaking ensures Positive Isolation.

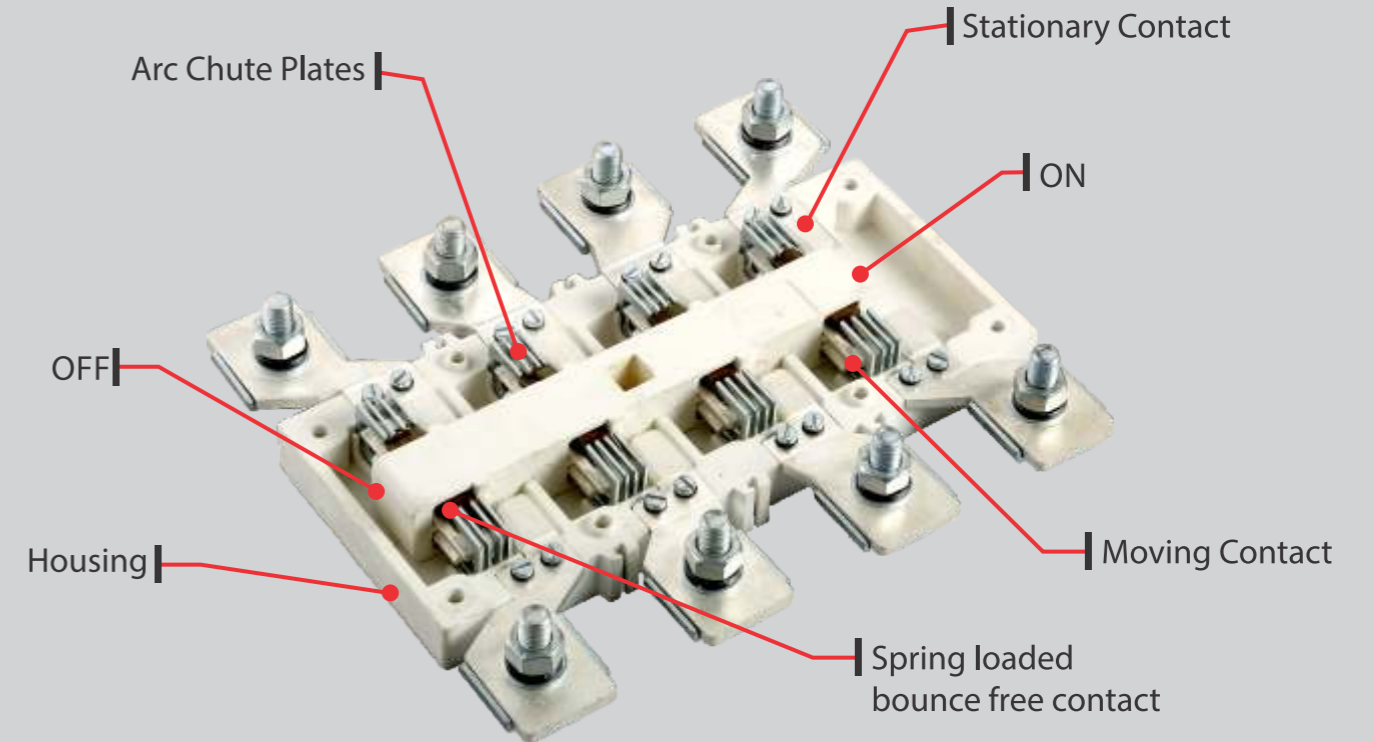

The Technology for Onload Changeover Switch

Arc Chamber

The Arc Chamber is specially designed to provide arc chute plates to channelise arc as a flow guide to reduce the arc length, there by improving the capability of extinguishing the arc with in the switch. This also enhances the life of the moving & stationary contacts thereby increasing the life of the product.

Body

Body parts are made of superior quality of thermoset plastics to withstand the stringent high temperature conditions where it may see very high thermodynamic stresses. Its high insulation strength avoids any damage to the product & better the dielectric property.



On Load Changeover Switches



Overview (Operations)

Direct

The pad lockable handle is mounted directly on the Onload Changeover switch and is lockable in both OFF & ON positions.

External

The pad lockable handle is mounted on the panel door with Spindle before the switch ensuring low maintenance cost and easy replacement. The external front operation ensures that the door is locked in ON position.

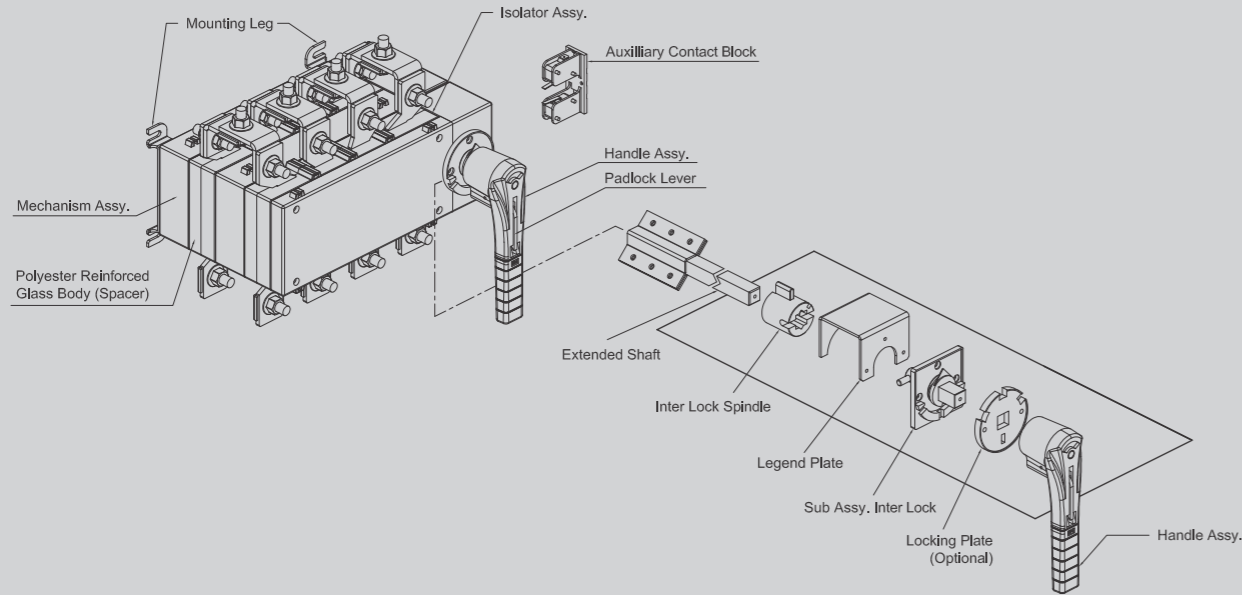

Accessories

Handle

The Changeover switch has a single hand operated handle upto 630A & two hand operated handle for ratings 800A Amps and above. The handle offers the following features:

- ▶ Provision for providing 3 padlocks in both OFF & ON Positions.
- ▶ Telescopic operating shaft for varied depth adjustment.

Handle up to 630A



Handle with padlock lever

Handle for 800A and above

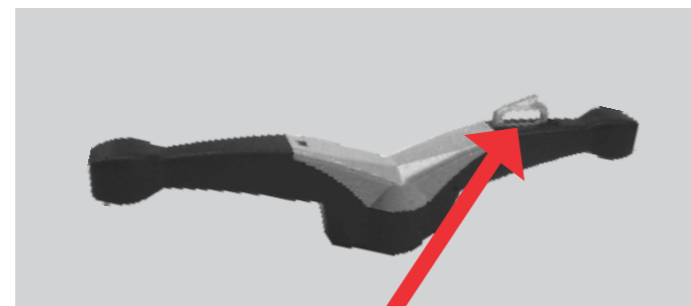

Double Sided Handle with padlock lever



On Load Changeover Switches



Accessories

Auxiliary Contact Kit

It consists of two auxiliary contacts, each with 1 NO + 1NC. This kit is pre-wired and can be fitted at the site in no time & saving the cost of wires.



Source Separator & Terminal Shroud

Made of transparent polycarbonate flame retardant material **Source Separator** is used to isolate two incoming supplies and to eliminate possibility of flash over between two supplies due to accidental falling of external objects.

Shrouds provide complete touch proof design and prevent accidental touching of live terminals. They are mounted on grooves provided on the switch

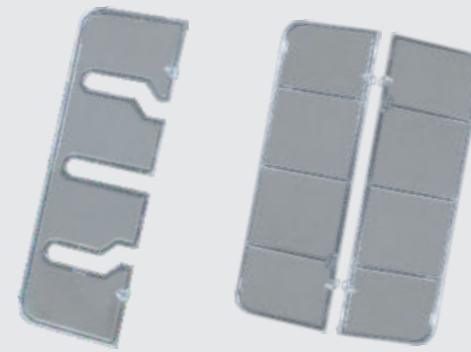

Inter-Phase Barriers

Made of transparent polycarbonate flame retardant material. **Inter-phase barriers** are provided for additional safety to eliminate possibility of inter-phase shorting.



Bridging Bars

Bridging bars are provided with all ratings to bridge top and bottom Isolators on one common side.



Extended Shaft



Door Inter Lock Assly.



On Load Changeover Switches



Specification
Electrical & Mechanical Characteristic

Specification	Current Rating							
	Frame-0			Frame-1			Frame-2	
Frame Sizes	63A	80A	100A	125A	160A	200A	250A	320A
Thermal Current (Ith) 40°C	63	80	100	125	160	200	250	315
Max. Normal rating of fuses	63	80	100	125	160	200	250	315
Insulation voltage Ui (Vac)	800	800	800	1000	1000	1000	1000	1000
Dielectric strength (Vac) 50 Hz 1 minute	4000	4000	4000	5000	5000	5000	5000	5000
Impulse voltage (KV)	6	6	6	6	6	6	8	8

Rated Operational Current Ie (A)

415 Vac: AC 23A	63	80	100	125	160	200	250	320
500 Vac: AC 23A	55	55	55	80	80	80	200	200
220V dc: DC 21A	63	80	100	125	160	200	250	250
220V dc: DC 22A	63	80	100	125	160	200	250	250
220V dc: DC 23A	63	63	63	125	125	125	200	200
440V dc: DC 21A	63	80	100	125	125	125	200	200
440V dc: DC22A	63	80	100	125	125	125	200	200
440V dc: DC 23A	63	63	63	125	125	125	200	200

Motor Power (KW) 415V

415 Vac without pre break Aux. Contact	30	30	30	63	70	80	132	160
500 Vac without pre break Aux. Contact	30	30	30	60	63	63	140	220
690 Vac without pre break Aux. Contact	22	22	22	50	55	55	90	150
415 Vac with pre break Aux. Contact	30	30	30	63	70	80	132	160
500 Vac with pre break Aux. Contact	30	30	30	70	80	80	160	220
690 Vac with pre break Aux. Contact	35	35	35	100	110	110	110	220
Motor Reactive 415 Vac (kVAR)	25	25	25	50	55	60	100	125

Overload Capacity

Short circuit current with fuses (kA RMS)	80	80	80	80	80	80	80	80
Fuse Rating	63	80	100	125	160	200	250	315
Peak short circuit making capacity (kA RMS)	15	15	15	20	20	20	30	45
Admissible short time current 1 sec (kA RMS)	5	5	5	7	7	7	13	13

Making & Breaking Characteristics

Breaking capacity (A RMS) 415 Vac pf=0.35	504	640	800	1000	1280	1600	2000	2520
Making capacity (A RMS) 415 Vac pf=0.35	630	800	1000	1250	1600	2000	2500	3150

Endurance

Mechanical Life (No. of Operations)	10000	10000	10000	8000	8000	8000	8000	5000
Electrical Life (No. of Operations)	2500	1500	1500	1000	1000	1000	1000	1000
Operating Torque (N-m)	3.5	3.5	3.5	9.5	9.5	9.5	11	11

Connection

Min. Cu. Cable / Bus bar size (mm ²)	16	25	35	50	70	95	120	185
Min. Al. Cable / Bus bar size (mm ²)	25	25X2	25X2	70	95	150	185	240



On Load Changeover Switches



Specification
Electrical & Mechanical Characteristic

Specification	Current Rating								
	Frame-3			Frame-4	Frame-5				
Frame Sizes	400A	630A	800A	1000A	1250A	1600A	2000A	2500A	3150A
Thermal Current (Ith) 40°C	400	630	800	1000	1250	1600	2000	2500	3150
Max. Normal rating of fuses	400	630	800	1000	1250	2 x 800	2 x 1000	2 x 1250	2 x 1250
Insulation voltage Ui (Vac)	1000	1000	1000	1000	1000	1000	1000	1000	1000
Dielectric strength (Vac) 50 Hz 1 minute	8000	8000	8000	8000	10000	10000	10000	10000	10000
Impulse voltage (KV)	12	12	12	12	12	12	12	12	12

Rated Operational Current Ie (A)

415 Vac: AC 23A	400	630	800	1000	1000	1000	1250	1250	1250
500 Vac: AC 23A	200	200	400	630	800	800	1000	1000	1000
260V dc: DC 21A	250	250	800	1000	1250	1250	1250	1250	1250
DC 22A	250	250	800	1000	1250	1250	1250	1250	1250
DC 23A	200	200	800	1000	1250	1250	1250	1250	1250
440V dc: DC 21A	200	200	800	1000	1250	1250	1250	1250	1250
DC 22A	200	200	800	1000	1250	1250	1250	1250	1250
DC 23A	200	200	800	1000	1250	1250	1250	1250	1250

Motor Power (KW) 415V

415 Vac without pre break Aux. Contact	200	220	450	560	560	560	710	710	710
500 Vac without pre break Aux. Contact	220	220	450	560	560	710	710	710	710
690 Vac without pre break Aux. Contact	150	150	185	400	400	475	475	750	750
415 Vac with pre break Aux. Contact	220	355	450	560	710	710	900	1100	1155
500 Vac with pre break Aux. Contact	280	355	550	710	710	900	900	1100	1100
690 Vac with pre break Aux. Contact	220	295	475	600	600	750	750	900	900
Motor Reactive 415 Vac (kVAR)	150	2 x 125	2 x 150	3 x 150	4 x 125	5x 150	6 x 150	7 x 150	9 x 150

Overload Capacity

Short circuit current with fuses (kA RMS)	80	80	80	80	80	80	80	80	80
Fuse Rating	400	630	800	1000	1250	2 x 800	2 x 1000	2 x 1250	2 x 1250
Peak short circuit making capacity (kA RMS)	45	45	55	105	105	110	110	110	120
Admissible short time current 1 sec (kA RMS)	13	13	26	50	50	50	50	50	55

Making & Breaking Characteristics

Breaking capacity (A RMS) 415 Vac pf=0.35	3200	5040	6400	8000	8000	8000	10000	10000	10000
Making capacity (A RMS) 415 Vac pf=0.35	4000	6300	8000	10000	10000	10000	12500	12500	12500

Endurance

Mechanical Life (No. of Operations)	5000	5000	4000	4000	4000	3000	3000	2500	2500
Electrical Life (No. of Operations)	1000	1000	500	500	500	500	500	500	500
Operating Torque (N-m)	17	17	40	40	40	40	60	60	60

Connection

Min. Cu. Cable / Bus bar size (mm ²)	30x5x2	40x5x2	50x5x2	60x5x2	80x5x2	100x5x2	100x5x3	100x5x4	100x10x3
Min. Al. Cable / Bus bar size (mm ²)	32x8x2	40x8x2	50x8x2	50x10x2	63x12x2	100x8x2	100x10x3	100x10x4	---



On Load Changeover Switches



Dimensional Details 4P: Changeover 63A To 100A

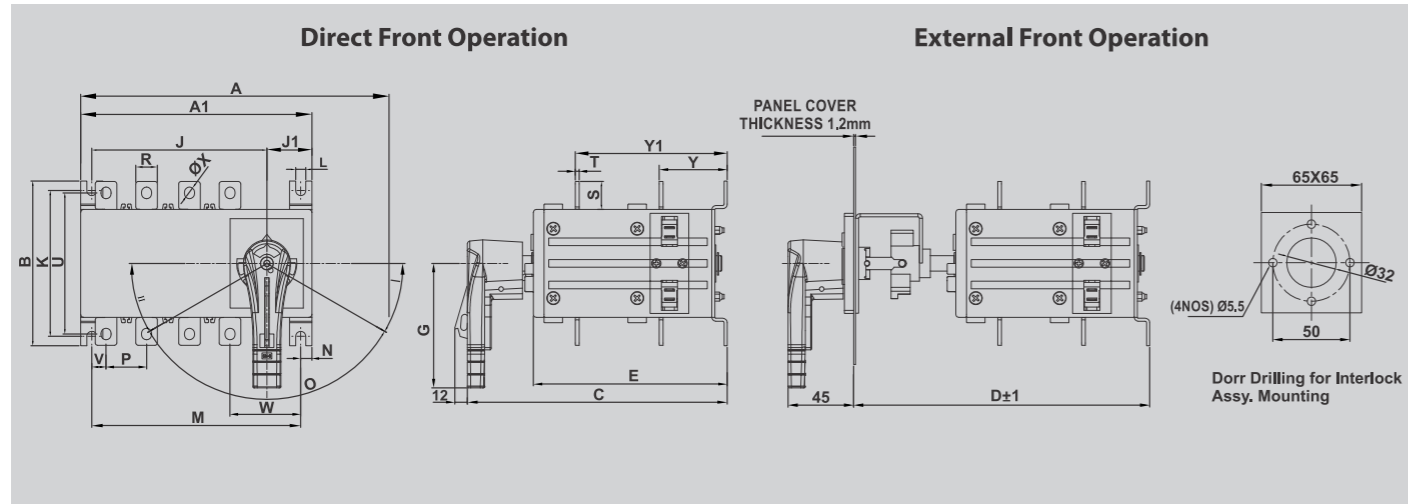

	Over All Dimension							Fixing of SW.					Connection Terminal							SW. W.T.					
	Rating	A	A1	B	C	D	E	G	J	J1	K	L	M	N	P	R	S	T	U	V	W	ØX	Y	Y1	Open Ex.
Frame-0	4x63A	190	150	106	183	192	126	80	114	30	95	6.5	135	7.25	27	14	18	2.5	91	9.25	46	6.5	44	99	2 Kg.
	4x80A	190	150	106	183	192	126	80	114	30	95	6.5	135	7.25	27	14	18	2.5	91	9.25	46	6.5	44	99	2 Kg.
	4x100A	190	150	106	183	192	126	80	114	30	95	6.5	135	7.25	27	15	18	2.5	91	9.25	46	6.5	44	99	2 Kg.

Note: All dimensions in mm (Tolerance ±5%)

Changeover 125A To 630A

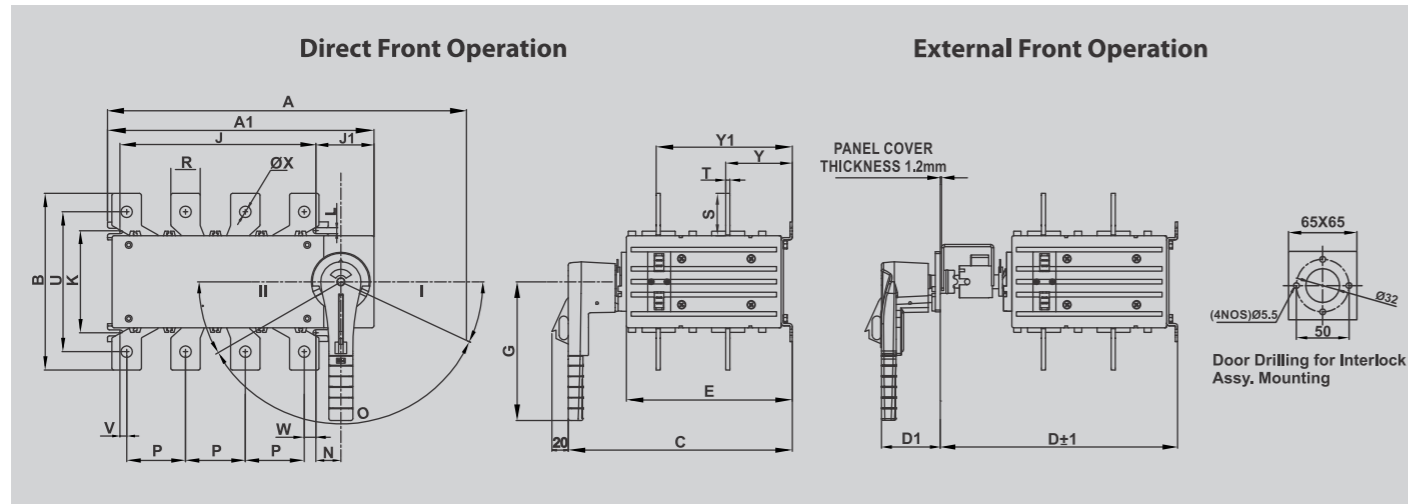

	Over All Dimension							Fixing of SW.					Connection Terminal							SW. W.T.					
	Rating	A	A1	B	C	D	D1	E	G	J	J1	K	L	N	P	R	S	T	U	V	W	ØX	Y	Y1	Open Ex.
Frame-1	4x125A	305	228	141	227	240	65	160	116	162	57	95	6.5	26	44	22	28	3	118	15	15	8.5	64	130	4.0 Kg
	4x160A	305	228	155	227	240	65	160	116	162	57	95	6.5	26	47	25	35	4	123	10.5	10.5	10	64	130	5.0 Kg
	4x200A	305	228	155	227	240	65	160	116	162	57	95	6.5	26	47	25	35	4	123	10.5	10.5	10	64	130	5.0 Kg
Frame-2	4x250A	390	290	192	244	258	65	180	150	217	61	111	6.5	27	64	32	46	4.5	152	9.5	15	12.5	72	148	7.3 Kg
	4x320A	390	290	192	244	258	65	180	150	217	61	111	6.5	27	64	32	46	4.5	152	9.5	15	12.5	72	148	7.3 Kg
Frame-3	4x400A	472	372	240	314	323	65	250	150	280	80	180	9	40	72	40	40	5	206	30	30	11	95	203	14.0 Kg
	4x630A	472	372	270	314	323	65	250	150	280	80	180	9	40	80	55	55	5	230	20	20	14.5	95	203	17 Kg

Note: All dimensions in mm (Tolerance ±5%)



On Load Changeover Switches



Dimensional Details 4P: Changeover 800A To 1600A

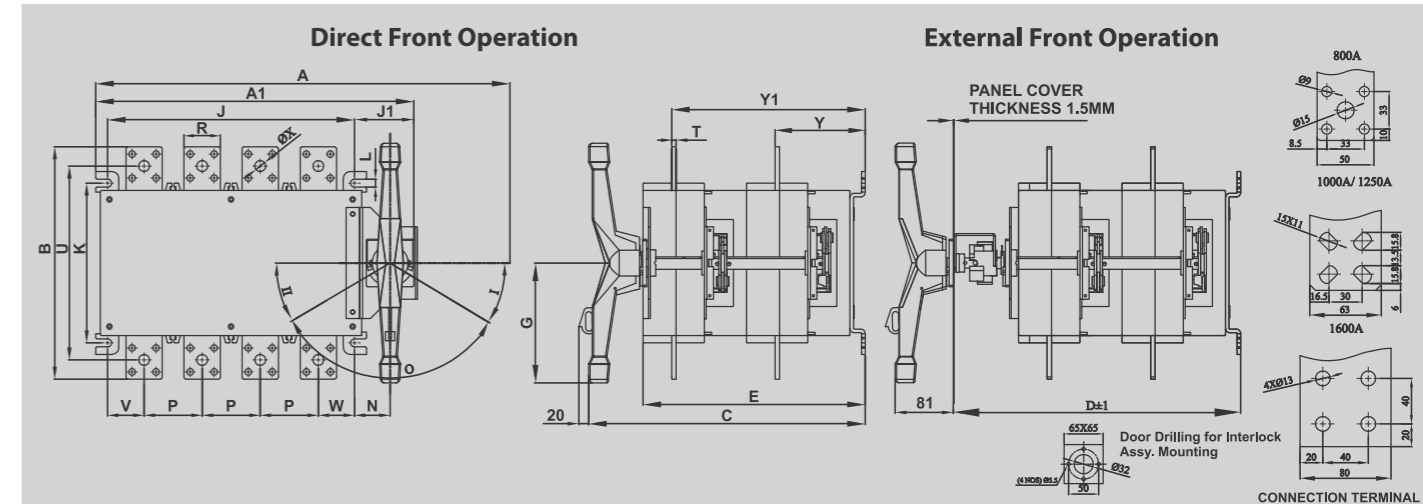

	Over All Dimension							Fixing of SW.					Connection Terminal							SW. W.T.					
	Rating	A	A1	B	C	D	D1	E	G	J	J1	K	L	N	P	R	S	T	U	V	W	ØX	Y	Y1	Open Ex.
Frame-4	4x800A	572	440	320	382	378	81	310	165	340	85	220	11	49	80	50	60	6	267	50	50	15	124	266	27.2 Kg
	4x1000A	700	575	330	382	378	81	310	165	474	85	220	11	49	120	63	65	6	273	63	50	--	124	266	35.3 Kg
Frame-5	4x1250A	700	575	330	382	378	81	310	165	474	85	220	11	49	120	63	65	7	273	63	50	--	125	267	37.0 Kg
	4x1600A	700	575	362	382	378	81	310	165	474	85	220	11	49	120	80	80	15	281	63	50	--	129	271	61.0 Kg

Note: All dimensions in mm (Tolerance ±5%)

Changeover 2000A To 3150A

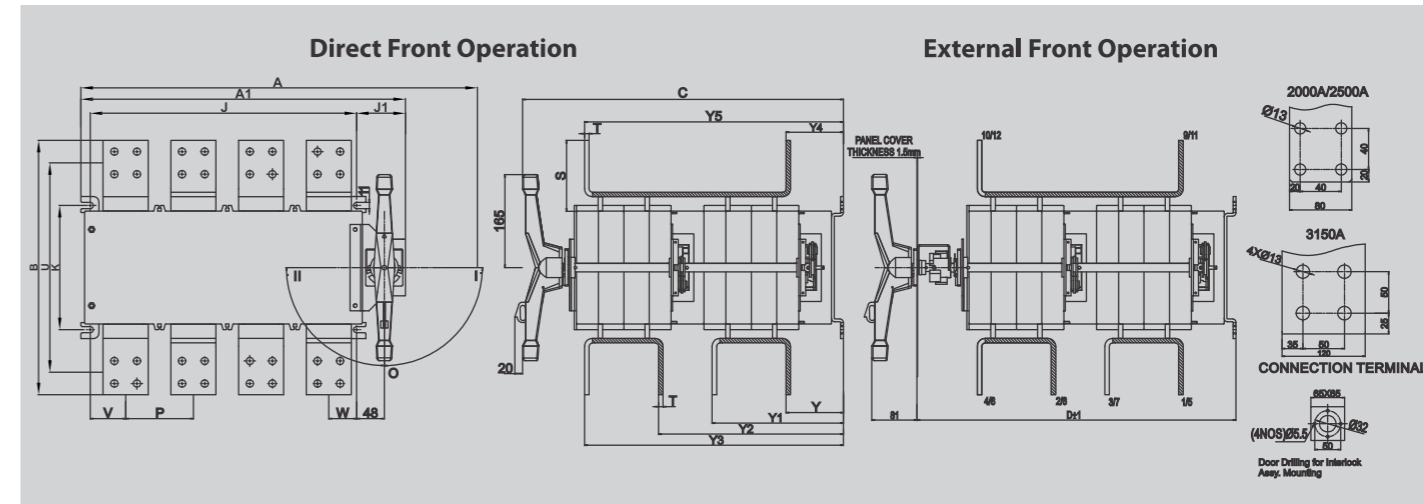

	Over All Dimension							Fixing of SW.					Connection Terminal							SW. W.T.
	Rating	A	A1	B	C	D	J	J1	K	P	S	T	U	V	W	Y/Y4	Y1	Y2	Y3/Y5	Open Ex.
Frame-5	4x2000A	703	575	450	570	566	474	85	220	120	125	8	371	64	50	102	233	328	459	72 Kg.
	4x2500A	703	575	450	570	566	474	85	220	120	125	10	371	64	50	100	237	326	463	77.4 Kg.
	4x3150A	703	575	500	570	566	474	85	220	120	150	15	401	64	50	94	248	320	474	110 Kg.

Note: All dimensions in mm (Tolerance ±5%)



On Load Changeover Switches



Dimensional Details 3P: Changeover 63A To 100A

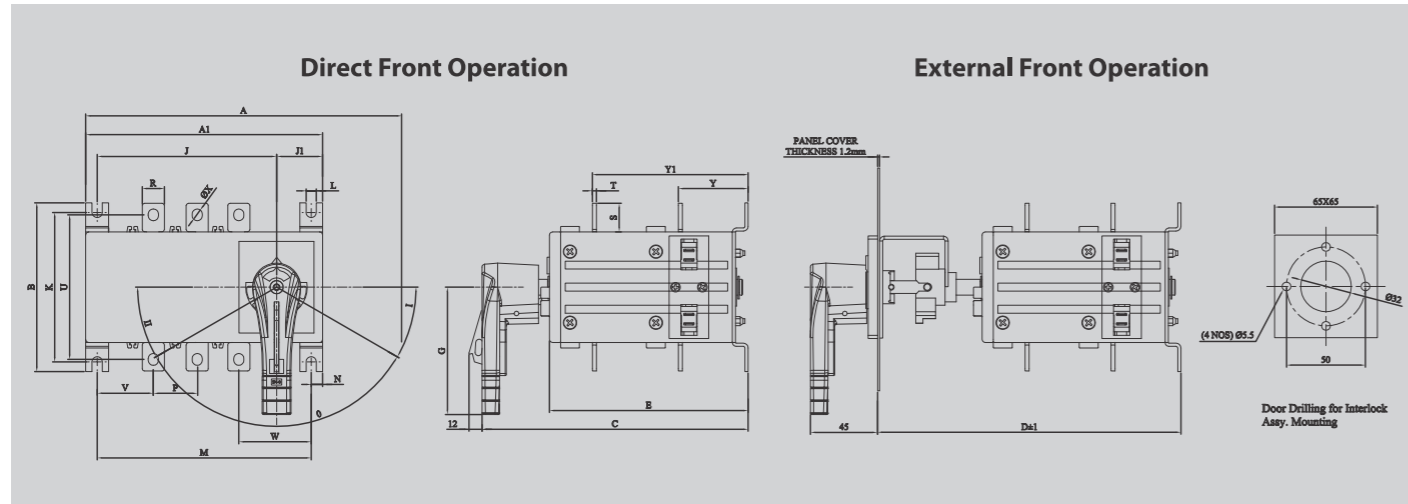

Over All Dimension		Fixing of SW.					Connection Terminal										SW. W.T.								
Rating	A	A1	B	C	D	E	G	J	J1	K	L	M	N	P	R	S	T	U	V	W	ØX	Y	Y1	Open Ex.	
Frame-0	3x63A	190	150	106	183	192	126	80	114	30	95	6.5	135	7.25	27	14	18	2.5	91	36	46	6.5	44	99	1.90 Kg.
	3x80A	190	150	106	183	192	126	80	114	30	95	6.5	135	7.25	27	14	18	2.5	91	36	46	6.5	44	99	1.90 Kg.
	3x100A	190	150	106	183	192	126	80	114	30	95	6.5	135	7.25	27	15	18	2.5	91	36	46	6.5	44	99	1.90 Kg.

Note: All dimensions in mm (Tolerance ±5%)

Changeover 125A To 630A

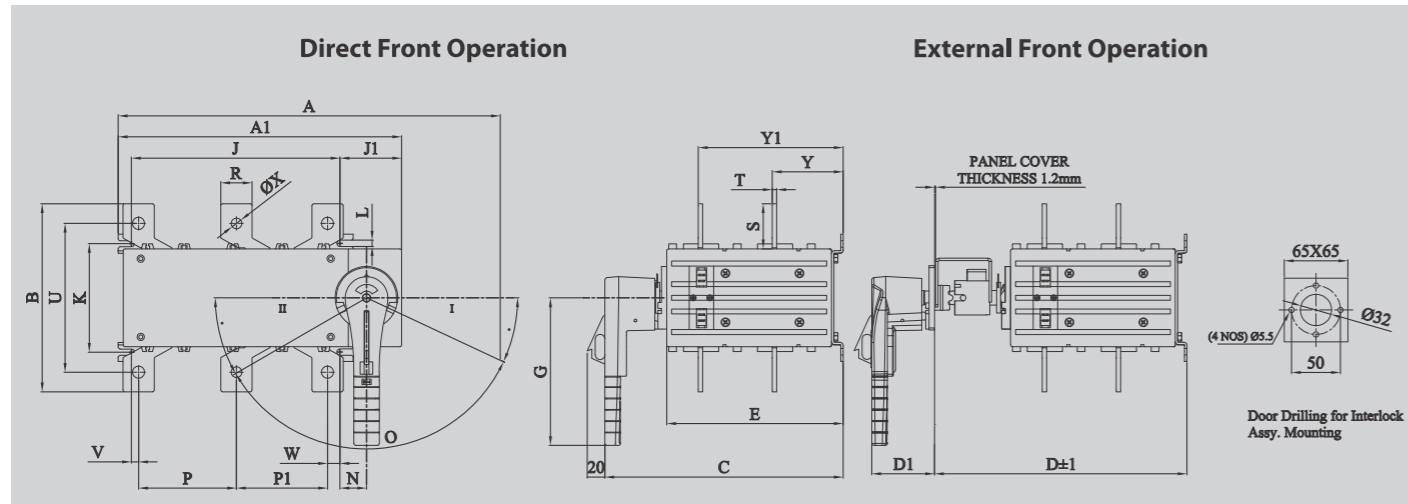

Over All Dimension		Fixing of SW.					Connection Terminal										SW. W.T.									
Rating	A	A1	B	C	D	D1	E	G	J	J1	K	L	N	P	P1	R	S	T	U	V	W	ØX	Y	Y1	Open Ex.	
Frame-1	3x125A	305	228	141	227	240	65	160	116	162	57	95	6.5	26	69	72	22	28	3	118	15	15	8.5	64	130	3.8 Kg
	3x160A	305	228	155	227	240	65	160	116	162	57	95	6.5	26	69	72	25	35	4	123	10.5	10.5	10	64	130	4.7 Kg
	3x200A	305	228	155	227	240	65	160	116	162	57	95	6.5	26	69	72	25	35	4	123	10.5	10.5	10	64	130	4.7 Kg
Frame-2	3x250A	390	290	192	244	258	65	180	150	217	61	111	6.5	27	93	100	32	46	4.5	152	9.5	15	12.5	72	148	6.8 Kg
	3x320A	390	290	192	244	258	65	180	150	217	61	111	6.5	27	93	100	32	46	4.5	152	9.5	15	12.5	72	148	6.8 Kg
Frame-3	3x400A	472	372	240	314	320	65	250	150	280	80	180	9	40	72	72	40	40	5	206	30	30	11	95	203	13 Kg
	3x630A	472	372	270	314	320	65	250	150	280	80	180	9	40	110	130	55	55	5	230	20	20	14.5	95	203	16 Kg

Note: All dimensions in mm (Tolerance ±5%)



On Load Changeover Switches



Dimensional Details 3P: Changeover 800A To 1600A

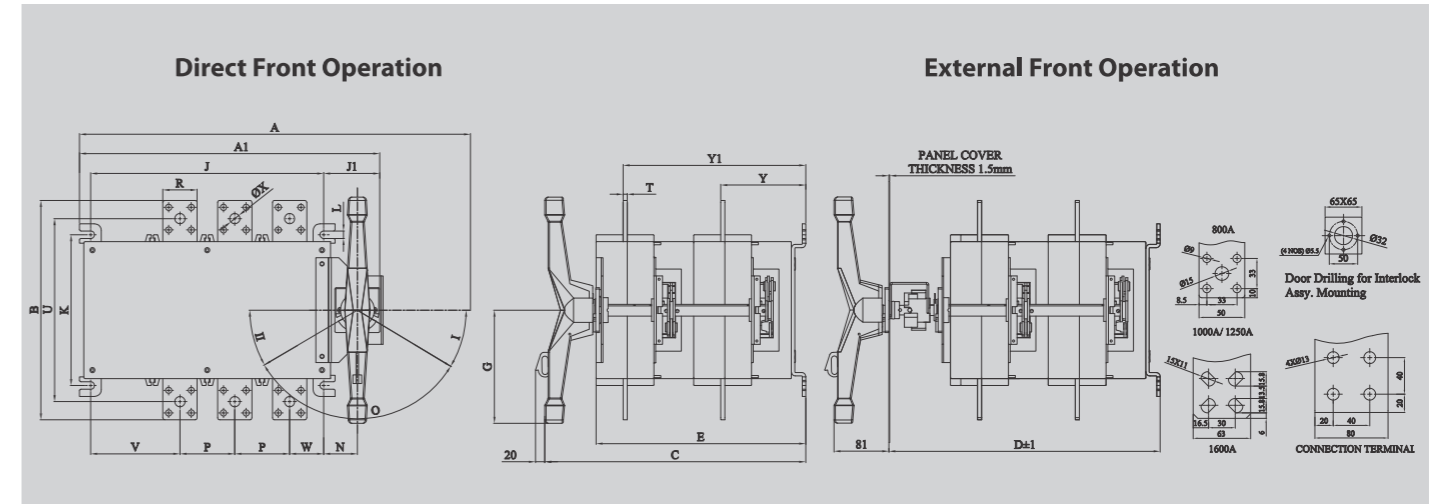

Over All Dimension		Fixing of SW.					Connection Terminal										SW. W.T.								
Rating	A	A1	B	C	D	D1	E	G	J	J1	K	L	N	P	R	S	T	U	V	W	ØX	Y	Y1	Open Ex.	
Frame-4	3x800A	572	440	320	382	378	81	310	165	340	85	220	11	49	80	50	60	6	267	130	50	15	124	266	25 Kg
	3x1000A	700	575	330	382	378	81	310	165	474	85	220	11	49	120	63	65	6	273	182	50	--	124	266	33Kg
Frame-5	3x1250A	700	575	330	382	378	81	310	165	474	85	220	11	49	120	63	65	7	273	182	50	--	125	267	34.5Kg
	3x1600A	700	575	362	382	378	81	310	165	474	85	220	11	49	120	80	80	15	281	182	50	--	129	271	58.5Kg

Note: All dimensions in mm (Tolerance ±5%)

Changeover 2000A To 3150A

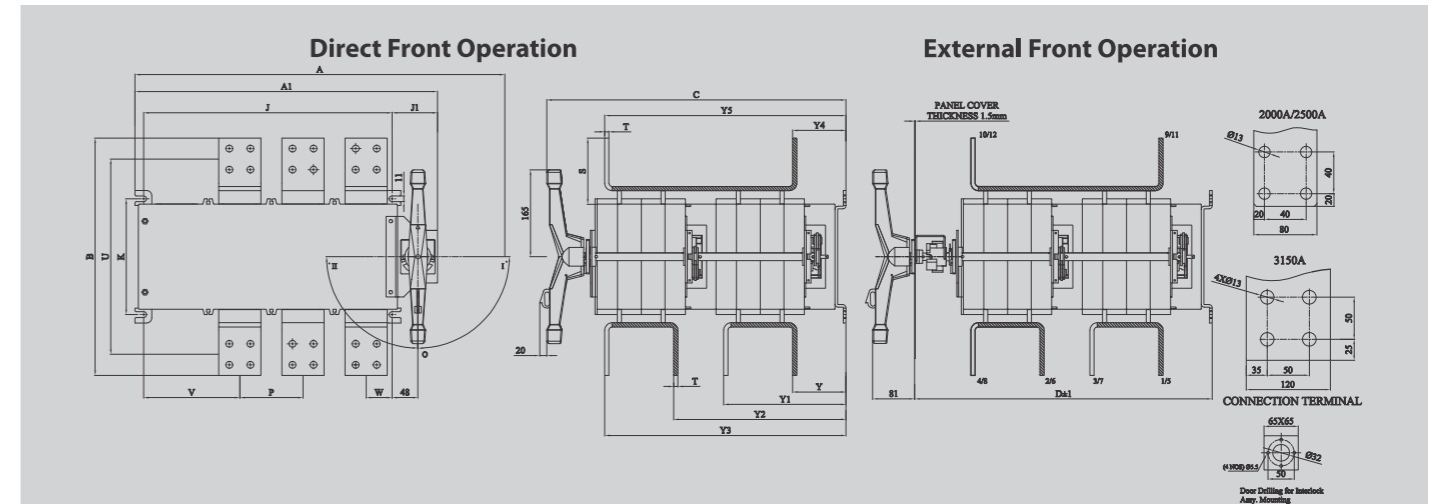

Over All Dimension		Fixing of SW.					Connection Terminal										SW. W.T.			
Rating	A	A1	B	C	D	J	J1	K	P	S	T	U	V	W	Y/Y4	Y1	Y2	Y3/Y5	Open Ex.	
Frame-5	3x2000A	703	575	450	570	566	474	85	220	120	125	8	371	182	50	102	233	328	459	65 Kg.
	3x2500A	703	575	450	570	566	474	85	220	120	125	10	371	182	50	100	237	326	463	71.5 Kg.
	3x3150A	703	575	500	570	566	474	85	220	120	150	15	401	182	50	94	248	320	474	100 Kg.

Note: All dimensions in mm (Tolerance ±5%)



On Load Changeover Switches



OnLoad C/O Enclosed



Function

- ▶ On Load manual changeover between 2 sources.
- ▶ Emergency Breaking.
- ▶ Selection between two loads.
- ▶ Safe isolation of downstream loads for maintenance purpose.

General Characteristics

- ▶ Black Handle Padlockable in I - O - II position.
- ▶ CRCA Sheet (Door 1.2 mm & Body 1.6mm) 63A to 800A.
- ▶ CRCA Sheet (Door 1.6mm & Body 2.0mm) 1000A to 3150A.
- ▶ RAL 7035.
- ▶ 2 External earthing points on each side.
- ▶ Wall mounted with 4 bolts.
- ▶ Door locking system allows opening of door only in OFF position.
- ▶ Incoming & outgoing easily interchangeable at site.
- ▶ Coating of epoxy polyester powder 70 micron.
- ▶ Removable plate top & bottom.
- ▶ Door with solid hinges.



On Load Changeover Switches



References and Dimensions

Rating	L	W	H	X	Y
63A-100A	215	255	215	215	245
125A-200A	290	365	265	325	320
250A-320A	350	455	282	415	380
400A-630A	475	575	345	515	525
800A	550	680	410	620	600
1000A-1600A	800	655	410	600	825
2000A-3150A	800	750	596	685	825

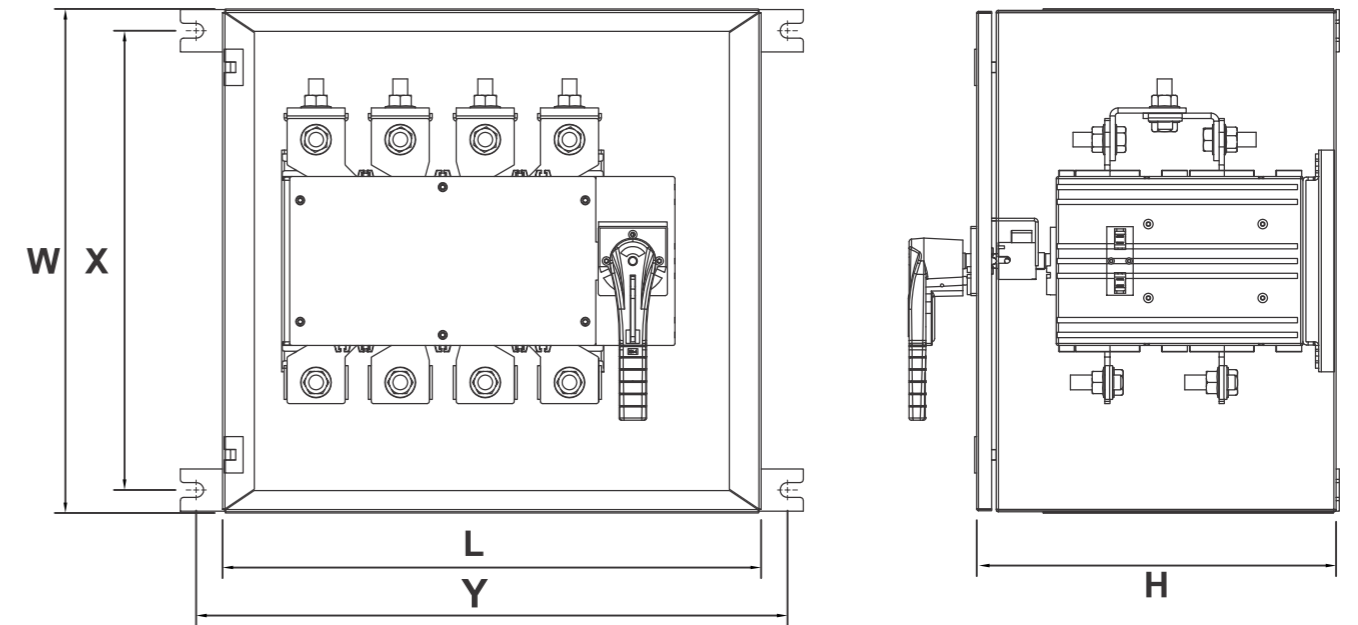

Note: All dimensions in mm (Tolerance ±5%)

Mounting Orientation

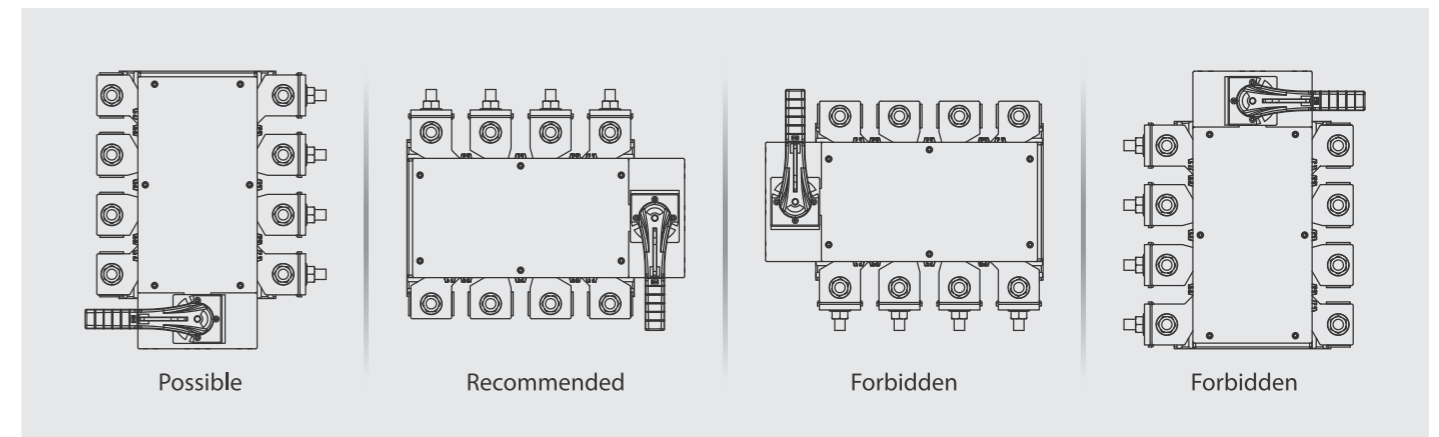



On Load Changeover Switches



Other Product Range

Load Break Switch

- Range : 63A - 3150A, 4 Pole, 415V AC.
- Conforms to IS / IEC 60947-3.
- Tested at CPRI Bhopal for AC-23A duty.
- Total Safety- all moving and live parts covered.
- Compact design.
- Quick make & quick break mechanism.
- Unique safety handle with door pad locking.
- Available in open execution and sheets steel enclosure.



Switch Fuse Changeover

- Range : 125 - 630A, 4 Pole, 415V AC.
- Conforms to IS / IEC 60947-3.
- Tested at CPRI Bhopal for AC 23A utilisation category.
- Total Safety- all moving and live parts covered.
- Silver plated current carrying parts.
- Flexibility for termination of supply.
- Mounting possible in both horizontal & vertical position.
- Available in Open Execution / Sheet Steel Enclosure.

By Pass Switch

- Range : 125A - 1600A, 4 Pole, 415V AC.
- Conforms to IS / IEC 60947-3.
- Tested for AC-23A utilization category.
- Total Safety- all moving and live parts covered.
- Switch is designed for specific need in IT industries where UPS and servo stabilizer provides main source of supply.
- Operated manually with double handle comfortably Switch.



On Load Changeover Switches



Other Product Range

Automatic Transfer Switch

- Range 125A-630A, 4P, AC 23A, 3 frame sizes.
- Trip Safety as standard feature, CE marked, RoHS Compliant.
- Power monitoring- kWh, kVAh, kVAR, kVARh.
- User selectable Rs232 & RS485 communications.
- Configurable over riding voltage parameters.
- Programable source priority.



ACB

- Range : 630A - 6300A.
- Operational voltage 690V & above.
- Icu 50kA to 120kA at 500Vac.
- Ics = 100% Icu throughout the range.
- Icw : 50kA to 100kA (for 1 sec).
- Customer oriented Trip Relay - with advanced measurement functions & communication functions.

Microprocessor MCCB

- Microprocessor range from 250A - 800A, Icu 36kA to 65kA.
- Adjustable overload, short circuit and ground fault with variable time setting and suitable for discrimination.
- Icu 36kA to 65kA, 3P & 4P (4PNutral fully protected). fixed and adjustable trip settings.



Controlgear

- Widest Range of 3P & 4P Contactors upto 800A.
- Capacitor Duty Contactors upto 62 kvar.
- Highest Electrical Life upto 2.5 million operations.
- Site mounted add on accessories (Auxiliary Contacts, Mechanical Interlock, Surge Suppressor, Timer, Mechanical Latch Units).
- Conformity to latest IEC/IS Standards.
- Type II Co-ordination. CE marked & UL Certified.

